



ELECTRIC CHARACTERISTICS

Nominal Voltage	0/250 V _{Ac} - 50/60 Hz
Phase to phase test voltage	1450 V _{Dc} (2 s)
Phase to ground test voltage	2150 V (2 s)
Climatic class	-25 / +85 °C



FIN35	Nominal current at 40°C (A)	C _x (μF)	R (kΩ)	L1 (mH)	C _y (nF)	L2 (μH)	Power loss (W)
.005.F	5	0,22	680	0,6	10	5	2
.010.F	10	0,22	680	0,6	10	5	2
.016.F	16	0,22	680	0,6	10	5	5
.024.M	24	0,22	680	0,6	10	5	5

Leakage current at 230 V phase to ground- 50 Hz / 40°C < 1,5mA

ELECTRIC DIAGRAM

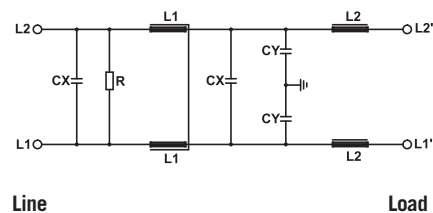

COMMON MODE ATTENUATION

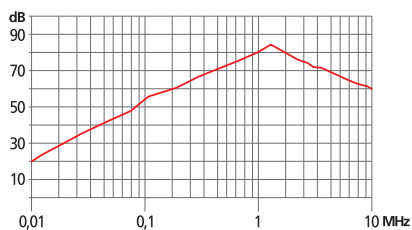

DIFFERENTIAL MODE ATTENUATION

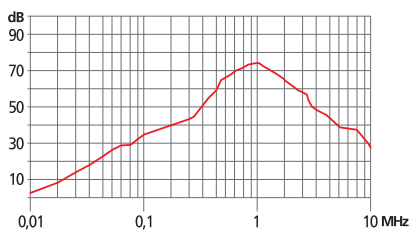

FIN40	Nominal current at 40°C (A)	C _x (μF)	R (kΩ)	L1 (mH)	C _y (nF)	L2 (μH)	Power loss (W)
.005.F	5	0,22	680	0,68	10	6	2
.010.F	10	0,22	680	0,68	10	6	2
.016.F	16	0,22	680	0,68	10	6	5
.024.M	24	0,22	680	0,68	10	6	5

Leakage current at 230 V phase to ground- 50 Hz / 40°C < 1,5mA

ELECTRIC DIAGRAM

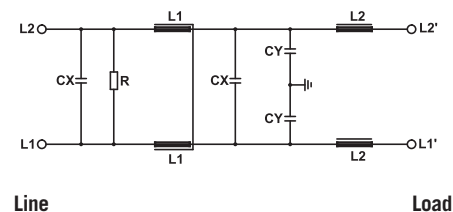

COMMON MODE ATTENUATION

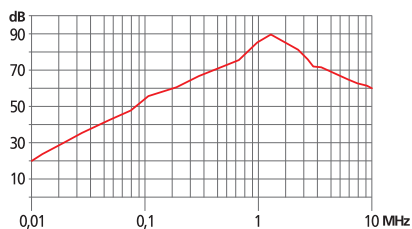

DIFFERENTIAL MODE ATTENUATION

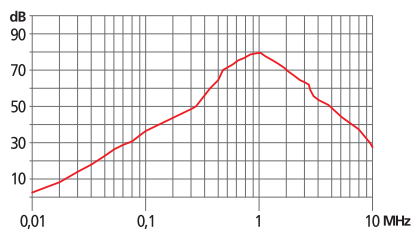

FIN50	Corrente nominale a 40°C (A) <i>Nominal current at 40°C (A)</i>	Cx (µF)	R (kΩ)	L1 (mH)	Cy (nF)	L2 (µH)	Cy2 (nF)	Pot diss (W) <i>Power loss (W)</i>
.005.F	5	0,22	470	4	4,7	4	10	1
.010.F	10	0,22	470	4	4,7	4	10	1
.016.F	16	0,22	470	4	4,7	4	10	2
.024.M	24	0,22	470	4	4,7	4	10	5

Leakage current at 230 V phase to ground- 50 Hz / 40°C < 2,2mA

ELECTRIC DIAGRAM

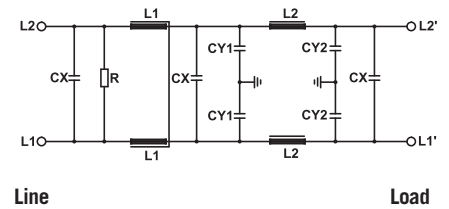

COMMON MODE ATTENUATION

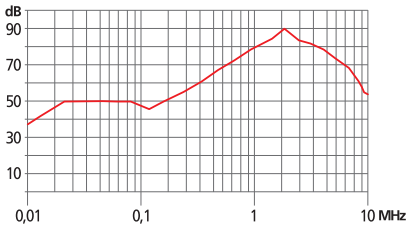

DIFFERENTIAL MODE ATTENUATION

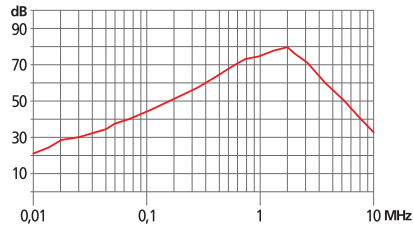

MECHANICAL DIMENSIONS (mm)

MODELLO <i>Model</i>	A	B	H	N	F	L	I	V	d	Weight Kg	Case
FIN35.005.F	29	51	84,5	—	4,5	74,5	63,5	13,5	6,5	0,13	2
FIN40.005.F	29	51	84,5	—	4,5	74,5	63,5	13,5	6,5	0,13	2
FIN50.005.F	39	51	84,5	—	4,5	74,5	63,5	13,5	6,5	0,2	3
FIN35.010.F	33	51	84,5	—	4,5	74,5	63,5	13,5	6,5	0,18	4
FIN40.010.F	33	51	84,5	—	4,5	74,5	63,5	13,5	6,5	0,18	4
FIN50.010.F	49,5	51	97	—	4,5	86,5	75,5	13,5	6,5	0,35	5
FIN35.016.F	39,5	51	97	—	4,5	86,5	75,5	13,5	6,5	0,26	6
FIN40.016.F	39,5	51	97	—	4,5	86,5	75,5	13,5	6,5	0,26	6
FIN50.016.F	45	84,5	104,5	95	6X4	51	99,5	13,5	6,5	0,7	7
FIN35.24.M	49,5	51	70	60	4,5	51	93	13	22	0,46	8
FIN40.24.M	49,5	51	70	60	4,5	51	93	13	22	0,46	8
FIN50.24.M	49,5	84,5	104,5	95	6X4	51	99	13	22	0,93	9

F = Faston – M = Terminals

The filter **FIN40.005** is also available with output on cable

ASSEMBLING

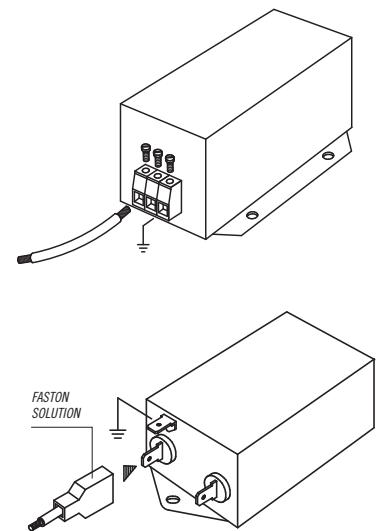

CASE 1

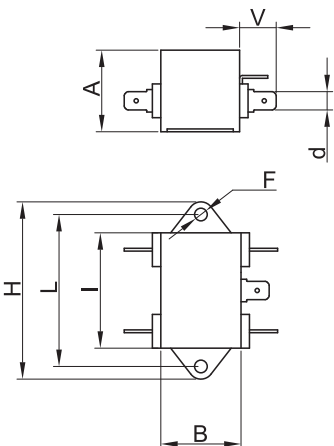

CASE 2/3/4/5/6

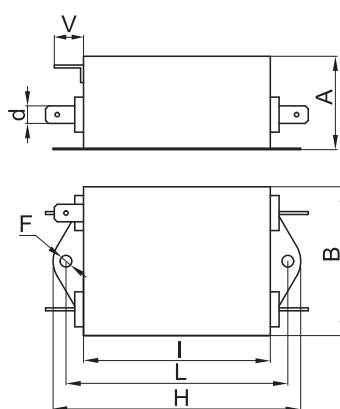

CASE 7

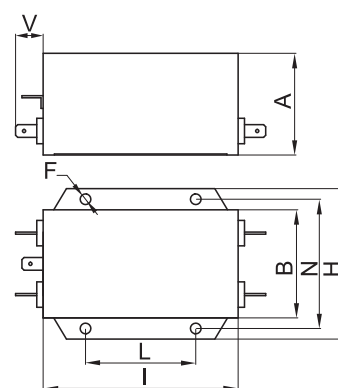

CASE 8/9

